



EXTRACTION + VENTILATION GUIDE

Contents.



04. Introduction



06. **THE PERFECT HOOD**
Choosing the Right Extractor



11. Extraction or Recirculation



16. Noise Levels

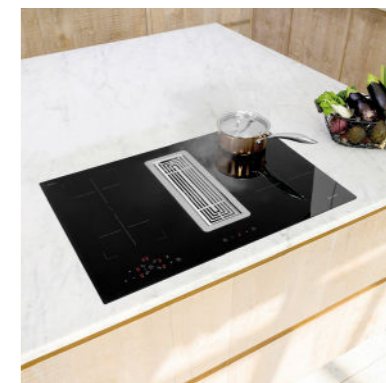

17. **CONSIDERATIONS**
Installation Considerations



19. At a Glance



20. **VENTILATION**
Ventilation Performance



22. **INSTALLATION HEIGHTS**
Heights + Safe Distances



24. **DUCTING**
Planning Exhaust Air Ducting



26. **EXHAUST MATERIAL**
Ducting + Shape



30. Cooker Hood Technology



34. Troubleshooting



36. Efficient Installation



37. Guidelines +
Recommendations



42. Contact Details

Making functionality fashionable.

Beautiful, functional and technically advanced, Caple appliances are central to the concept of a contemporary kitchen.

From super sleek induction hobs to discretely effective cooker hoods, whisper quiet dishwashers and smart [in every sense] wine cabinets, they cater for every lifestyle.





Choosing the perfect hood.

Cooker hoods are designed to remove airborne grease, odours, and cooking fumes from your kitchen and save the surrounding area from getting as greasy. With a choice of ventilation methods, cooker hoods can be used in any type of home. Take a look at our full range can be viewed at www.caple.co.uk.



Downdraft extractors.

The Down draft hood design [width 60 or 90 cm] is built into the worktop behind the hob and can sink into the worktop. Instead of being extracted upwards, vapour is drawn backwards and downwards. The fan is located in on the extractor body or a separate fan can be sited in a cupboard, under the floor or on the outside wall.

This type of extractor uses edge extraction and its high performance provides effective and particularly quiet vapour extraction. Retractable Down draft hoods can be used in cooking islands.

Downdrafts in Extraction Mode:

- › **ALWAYS** use rigid ducting 6 inch [150mm diameter] circular or rectangular [90 x 220mm].
- › Never exceed 5 metres for duct run with DDMEXT11, DDMEXT21, DDMEXT25, DDMEXT30 + DDMEXT40 motors.
- › Remember to reduce the amount of 90 degree bends used in the duct run + allow 1 metre reduction on run for every 90 degree bend, so 2 x 90 bends will only allow a run of 3 metres.
- › Remember bends reduce air flow efficiency + increase noise levels.
- › If ducting outside always try to use the shortest route.
- › The vent to the outside should have slats as wide as possible, so the air can flow out with minimum restriction + must be the same size as ducting, no reducers.
- › If air goes out, air has to come in. So it's important that the kitchen has a fresh air supply, either through a window or an opening to the outside.

Downdraft in Recirculation mode:

- › **ALWAYS** have vents in the plinth as this will allow air pressure to enter back into the room from pressurisation of plinth zone.
- › Use small rigid duct piece [150mm] on a DDMEXT11 motor inverted downwards so duct goes through cupboard base [hole cut out] + directs air flow into plinth zone.
- › Try to use the dedicated DDMEXT28 motor for re-circulating kitchen designs.
- › Always use charcoal filters.

Top Tip: Always turn appliance ON 10 minutes before cooking + run for 15 minutes after cooking.





Induction Downdraft Extractor.

Seamless and stunning the induction DD940BK downdraft combines elegant looks with advanced functionality. With our innovative Plasma technology, allowing you to recirculate the air efficiently removing any trace of odours. With this product, you have the option to use our new Plasma technology. This allows you to recirculate the air with this very efficient odour removal process.

The motor, plasmabox and charcoal filter are cleverly hidden away in the plinth below the cabinets, so no need to duct the product to the outside wall. You can also install all the pipework into a 300mm wide carcass space allowing for a lot more use of the kitchen cupboard when compared to a conventional downdraft.

How does it work?

The grease and moisture is captured in the aluminium filter. The contaminated air stream [odours, vapours, etc.] is converted by a chemical reaction in the Plasmabox, the air is then passed through a carbon filter and clean air is recirculated back into the room.



Chimney Hoods.

This type of hood is decorative and is used if the hob is located in front of a wall. Chimney hoods are made from stainless steel and glass in some cases, they are available in a range of sizes and styles.

They all provide either surface or edge extraction and are mainly available in 60cm, 70cm and 90cm. The exhaust air can be routed through the wall behind the hood or through a lateral extractor duct. Chimney hoods can be integrated as a design element between wall units or placed freely on the wall.



Built-in Hoods.

Build-in hoods are installed in a wall unit. The exhaust ducting can be routed through the ceiling or laterally along the wall units. Built-in hoods allow for space to be used to optimal benefit in the kitchen.

Telescopic

This hood version is either completely hidden in a wall unit or installed so that only the narrow stainless steel bar of the vapour shield can be seen beneath the wall unit. Before this cooker hood can be used, the vapour shield must be extended like a telescope so that it covers the hob area.



Integrated Hood.

[Built-in hood behind a cabinet door]

These cooker hoods fill an entire wall unit or are installed between two wall units and fitted with a fold-out cabinet door or stainless steel front. The hood cannot be seen when closed.

The front plate opens forwards/upwards when using the hood. This creates a vapour trap behind the plate and in front of the inclined grease filters. The vapours are extracted using surface extraction.



Ceiling Hoods.

A ceiling extractor is a flat cooker hood that is preferably installed directly above the hob in a [suspended] ceiling. Ceiling extractors are particularly suitable for cooking islands, especially when an unimpeded view of the living/dining area is required. However, they also provide a visual highlight when placed above other cooking areas. Ceiling extractors feature edge extraction. Ceiling extractors are available in a width of 90 to 110cm with a recommended distance of up to 1500mm, depending on the hood. They are controlled via a remote control.



Conventional Hoods.

Conventional hoods are used either beneath a thin wall unit or mounted directly to the wall above the hob. When mounted on the wall, a conventional hood can be combined with a flue fixture [stainless steel telescopic flue]. This provides a kitchen appearance. These hoods provide surface extraction.



Island Hoods.

These decorative cooker hoods made from stainless steel, and glass in some cases, are used in modern kitchens with a cooking island. Island hoods provide either surface or edge extraction and are mainly available in 36 to 90cm widths. Island hoods are mounted to the ceiling. Telescopic flues allow these hoods to be used in different room heights. The exhaust air can be routed through the ceiling or through a lateral extractor duct. When selecting an island hood, it is important to keep an eye on overall proportions in the kitchen. Above all, it should not interrupt the view of the living/dining area.



Designer Hoods.

Available in widths of 60, 80 and 90cm, our designer hoods are fitted with vertical or diagonal surface or edge extraction units. The vapours extract upwards/backwards. Grease filters are covered by panels made from stainless steel or glass. The rising vapour is sucked through the gaps between the panels and into the grease filter.

The filters tend to be covered by a sealed glass plate. The glass plate opens forwards/upwards when using the hood. This creates a vapour trap behind the plate and in front of the inclined grease filters.



Island Hoods.

[with cables]

These contemporary extractors are also designed to be on a hob above an island. However, the extension cables provide more flexibility to accommodate different ceiling heights. The exhaust air can be routed through the ceiling or through a lateral extractor duct. These island hoods are great for making a statement in your home, with finishes such as copper, black and gold, or if you're after a more subtle look, then opt for stainless steel.

Choosing the right extractor.

Airflow

An important point to be checked is the required airflow for you extractor, normally this depends on the size of kitchen and also the type of cooking. The correct airflow for an extractor can be easily worked out, simply multiply the volume of the room by ten and you will obtain the ideal airflow for your kitchen.

For example for a kitchen size of 4m x 4m with a height of 2.7m: $[4 \times 4 \times 2.7] \times 10 = 432$. Therefore any product with the airflow of 432 m³/h will provide efficient ventilation.

Size

The extractor should cover at least the width of the hob. For induction hobs we recommend an extractor that is wider than the hob surface. This is as vapours will dissipate outwards when compared to a gas hob where vapours rise vertically in a candle flame-like shape.

Ducting

It is important to use the correct diameter ducting, all Caple extractors state the minimum spigot [for example 150mm] in the appliance brochure, on the website and in the instruction manual. Reducing the size of the ducting will also reduce the performance of the extractor and increase the noise level. In addition to this it will also void the warranty as the product had not been installed as advised in the installation instructions.

Recirculate

If you are unable to duct the extractor to the outside, you can recirculate the air by installing a charcoal filter. This works by the air being drawn through the charcoal filter which removes odours before it is released back into the room.

Note: In this mode humidity can not be reduced.

Hob distance

When installing the cooker hood, the minimum distance between the hood and hob must be observed. These will be stated in the instruction manuals, and the greatest distance stated should be used.

Guide recommended: Electric 650mm, Gas 760mm

Use

Extractors are designed to remove grease odours and vapours. To achieve the best results when using which ever extractor you choose, we recommend switching on the extractor 10 minutes before cooking and to leave it running 15 minutes after you have finished.

This will ensure that the air in the kitchen is being circulated before cooking commences and the air continues to be cleaned for a short while after, giving you the best results.

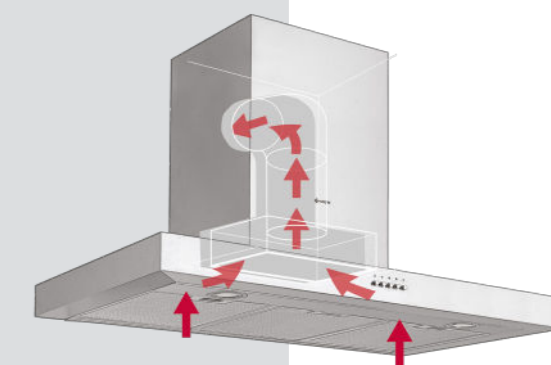

Extraction or recirculation.

Extraction.

In extraction mode, cooker hoods use a fan to draw in vapours, pass the vapours through a grease filter made from metal [permanent filter] to remove the grease for hygiene reasons and blow the filtered air outdoors. By removing vapours generated, this system also diverts excess moisture, heat and odours outdoors. The fan is usually located inside the cooker hood. Models with an external fan attached to the outside wall, for instance, are also available [see downdrafts and ceiling hoods].

The filtered air is conveyed from the room to the outside via ducting and a wall vent or via the roof. Fresh air must be supplied at the same time to prevent the formation of negative pressure. In other words: Exhaust air needs intake air.

Note:

Structural factors may prevent use in some situations [need to break through a wall, lay an air duct]. Energy loss through heat extraction. Optimal exhaust air routing required for high airflow volumes. Current Building regulations [e.g. BSEN 14134].

Benefits:

- › High airflow rate
- › Excess vapours moisture is conveyed outdoors
- › High effectiveness at low hood settings
- › No regular replacement costs for metal filters
- › Usually quieter than re-circulating hoods if correct ducting is used and installed correctly
- › No additional costs for active carbon filters

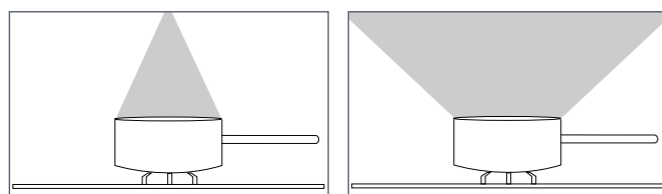

Tip:

The hood should cover at least the width of the hob. For induction we recommend a cooker hood that is wider than the hob, ideally surface extraction. This is because the vapours dissipate outwards opposed to gas where the vapours rise vertically.



Recirculation Mode.

In recirculation mode, cooker hoods use a fan to draw in vapours, pass the vapours through a grease filter made from metal [permanent filter] to remove the grease for hygiene reasons and then absorb the odours using an integrated active carbon filter. The cleaned air is then conveyed back into the room. Recirculation mode involves a closed circuit as there is no exchange with the outdoor air. This prevents the loss of heat. It is, however, important to ventilate the room after cooking [intensive airing] as excessive moisture can not be removed.

The cooker hood should also be left running for around 20 minutes after cooking to remove any odours present and dry out the odour filter. Re-circulating hoods are used in kitchens and houses where it is not possible to convey the air outdoors for structural reasons.

Tip.

Unless wall units are to be installed directly adjacent to the cooker hood, it is advisable to leave an adequate distance between the cooker hood and walls or kitchen cupboards when planning to use a recirculation hood. This will reduce the amount of turbulence. A distance of approximately 1-2 metres [from chimney to wall] can be used as a guide value.

The more powerful the ventilation, the greater the distance should be.

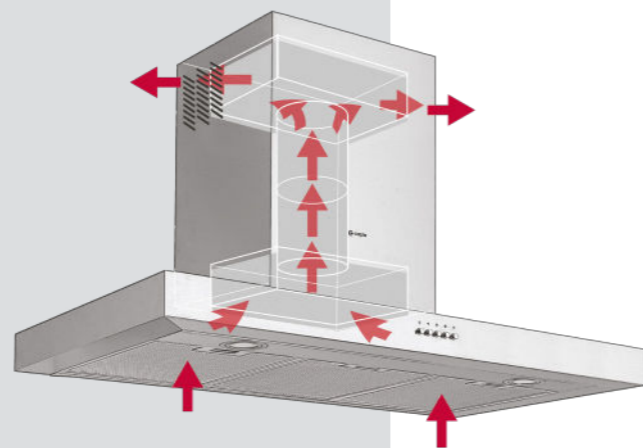

Note:

Moisture must be removed through additional intensive airing [leading to a loss of heat]. Active carbon filter requires regular cleaning/replacement. Cost of filter replacements. Usually louder than an extraction hood [depending on the routing of air]. Airflow rate is reduced by the active carbon filter.

Benefits:

- › Easy installation
- › No additional structural work required [no need to modify walls]
- › Hardly any loss of energy due to the discharge of warm indoor air through the cooker hood over a long period of time

Induction downdraft with plasma.

Downdrafts are a way of keeping cooking fumes and smells away from the rest of your house and kitchen. All hobs require extraction, but not every kitchen can fit a dedicated vent hood above the cooking surface.

That's where downdraft design comes in. Instead of pulling air up into a hood, it pulls vapours and odours down through a vent in the middle of the hob. From there it can either be exhausted or recirculated.

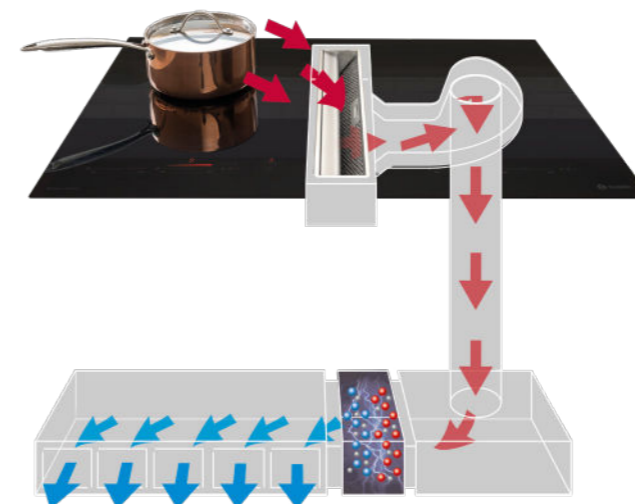

Benefits:

- › Manufactured in Germany
- › 5 years guarantee
- › Plasma technology
- › Limited space required in the cabinet below

Note:

The Plasma technology also extends the life of the charcoal filter from around 6 months to 5 years, 1 filter will last the equivalent of 10 without the Plasmabox.

How does the plasma filter work.

Plasma is the fourth state of matter, you have all heard of Solid, Liquid and Gas... the next state is Plasma. Naturally occurring plasma can be found in lightning and our Sun. Plasma occurs when gases are either heated to extremely high temperatures or subjected to a strong electromagnetic field.

The plasma extractor works in 3 phases:

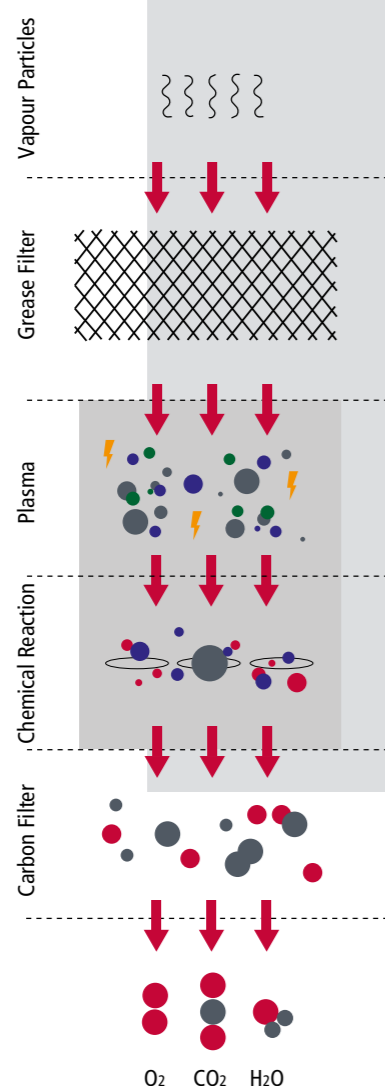

Phase one.

Grease extraction and dehumidification of the cooking vapour via the 12 layer aluminium filter.

Phase two.

The plasma box adds energy [1.5kV at max. 20 watt of energy is charging through the system transformer] to create Plasma through an electric barrier discharge.

Odour molecules as well as molecule chains are disintegrated and oxidised through a Plasma chemical reaction by adding oxygen and hydroxyls.

The energy discharge is also creating a limited amount of O_3 , which is reaction friendly with scent molecules and molecule chains. The chemical reaction with O_3 causes it to lose one O atom and it is then reduced to O_2 .

Phase three.

Odour molecules and molecule chains not captured in phase two will be absorbed by the active charcoal filter where all elements are completely oxidised.

The charcoal filter acts as a reactive catalyst, regenerating ozone back into oxygen. This in turn causes a regenerating reaction for the charcoal filter resulting in a substantially longer life for the filter [replacement period approximately 5 years]. Meaning one filter can be used in the place of 10 over the 5 year period, a great cost saving. Clean air [O_2 , CO_2 and H_2O] is released back into the room.

Visit: www.caple.co.uk for more details.

Surface or edge extraction.

Surface extraction.

Surface extraction is the most well known and most common form of extraction used in cooker hoods. The vapours generated when cooking are extracted across large parts or the entire surface of the vapour screen and conveyed through the immediately adjoining grease filter[s]. This design is characterised by particularly good extraction of vapours at the centre of the cooker hood and is recommended when using cookware that creates a particularly large amount of vapour, see chapter "Information on woks, deep fat fryers, grill pans and similar".



Edge extraction.

Edge extraction is a more recent variant among cooker hoods and is often considered to be more aesthetically appealing. In this design, the grease filters above the hob are covered by a glass or metal panel. The rising vapours are extracted only at the edge of the cooker hood through a gap [or several gaps] between the panel and the cooker hood housing and then passed through the grease filter[s]. This design offers high airflow speeds around the gaps of the cooker hood. As a result, extraction can be highly effective, especially if the vapours are generated towards the edge of the hob, and the cooker hood can be operated very effectively at lower power settings. The hood also creates a kind of suction curtain that prevents vapours from escaping to the side.

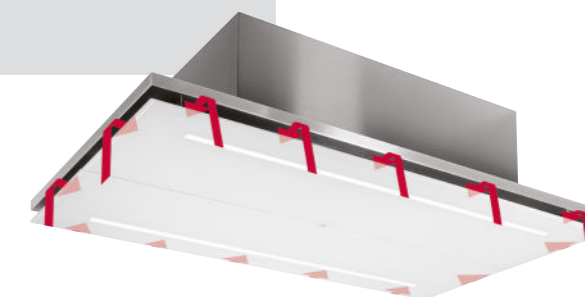

Noise levels.

Noise is generated by pressure waves that are emitted by an acoustic source, travel through the air at a speed of around 333 m/s and are registered as sound in the human ear. What a person hears is actually acoustic pressure. The acoustic source [the cooker hood, in this case] emits the acoustic or sound power. Both of these values can be measured and are indicated as:

- › Sound pressure level in dB [A]
- › Sound power level in dB [A] re 1 pW

The sound pressure level refers to the volume at a certain distance [e.g. 1 m] from the source of the noise [emission]. Since the sound pressure level is dependent on the measuring conditions [distance, reverberation and size of the room, etc.] and can be compared only under identical measuring conditions. It is not suitable for providing comparative noise information. Sound pressure is indicated in dB [A] [decibels, A weighting].

Note:

Small ducting = Increases vibration / oscillation noises.

Sound power of different noise sources.

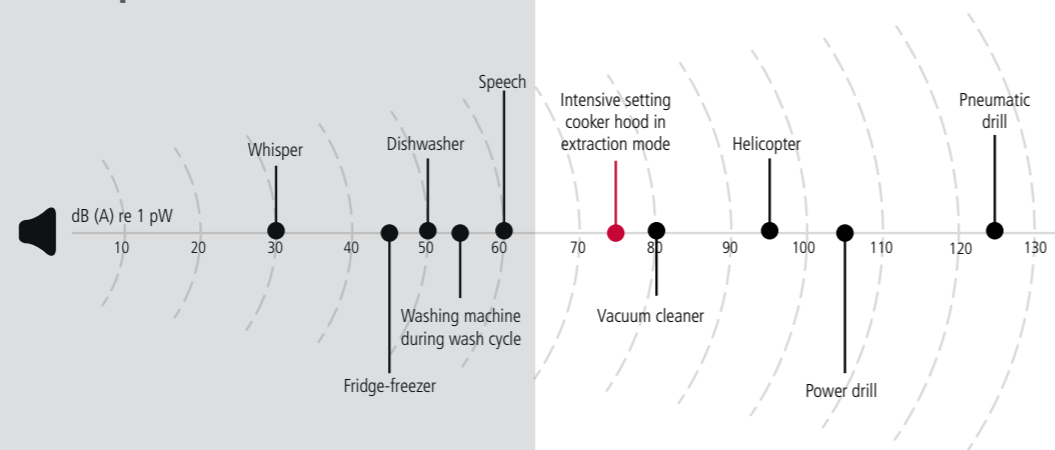

All values are examples. Values may differ depending on the model, ducting, and room size.

Decibel figures for appliances do not include ambient noise

The sound power level refers to the volume that originates [is emitted] directly from the acoustic source. Since it is measured directly at the source of the noise, this measurement can be standardised more easily and the values are better suited for comparison purposes. Sound power is indicated in dB [re 1 pW] [decibels, relative reference level 1 picowatt]. The standardised procedures for measuring sound power are described in **international standard IEC 60704-3**.

The sound power level of cooker hoods is dependent on the selected power level and lies between 40 and 70 dB [A] re 1 pW. Airflow noises in the extractor ducting have a stronger impact on noise levels than the cooker hood itself. It is therefore very important to observe information about creating low-noise extractor duct layouts when planning the ducting [see chapter "Information on exhaust air ducting"].



Installation considerations.

One of the most important considerations when designing and installing a kitchen, is the ventilation and ducting, please remember all appliances create heat and gas appliances also release moisture. Up to 45% of service interventions on new installations are to try and resolve issues with heights of cooker hoods above hobs, inadequate ventilation, poorly planned ducting and undersized duct work. For a cooker hood to perform quietly and efficiently a number of factors need to be taken into consideration, this guide covers most if not all areas. The moisture / grease and odours released during cooking pose a challenge with regard to ventilation and hygiene in the kitchen.

Ventilation.

Rooms can be ventilated naturally by opening windows and doors or electrically using motorised appliances such as cooker hoods. A high level of air exchange is particularly necessary in kitchens as an increased level of fumes and vapours is released while cooking. Using open windows as a means of ventilation and extraction tends to provide unreliable result as the level of ventilation is dependent on temperature and wind conditions. The greater the temperature difference between indoors and outdoors, the larger the lifting force and the greater the exchange of air. The exchange of air can be increased by strong wind or by opening additional windows or doors [creating draughts].

This uncontrolled exchange of air does, however, result in the loss of energy and heat. Using windows as a means of ventilation does little to remove grease particles. The only way to ensure proper ventilation and extraction in a kitchen is to properly control the exchange of air. Cooker hoods are therefore used to ventilate and extract air from kitchens. Cooker hoods speed up the exchange of air within the kitchen, filter out grease particles and neutralise odours. When operating in extraction mode, they also convey a high percentage of vapours outside of the kitchen.



Moisture.

A large amount of water is used when cooking food such as rice, pasta or soup on the hob. Water boils at a temperature of approx. 100 °C and then releases a large amount of steam. This releases approximately 1.5 litres of moisture into the kitchen over the course of a day. Once the air in the room is saturated with water vapour, the steam condenses on walls, windows and furniture. If this moisture remains in the room, it can lead to excess humidity and therefore to the formation of mould, structural damage and swollen, distorted wood [kitchen fittings], as well as creating an unpleasant and unhealthy room climate. In energy-efficient houses, it is particularly important to provide an efficient means of removing moisture in order to promote a pleasant room climate and prevent the formation of mould. Excess moisture can only be removed through adequate and correct ventilation. It is important that the moisture is removed at the point and time of origin. Preferably through a cooker hood in extraction mode [if permissible], a permanent ventilation system or intensive airing after cooking. Most people find a relative atmospheric humidity of between 40% and 60% to be pleasant. The level at which the air feels "too dry" or "too humid" is also determined by the room temperature.

Grease.

When cooking with fat or oil, small particles of grease are released into the air and create a thin film on fittings, appliances and walls. These grease deposits not only trap dirt but also pose a hygiene risk as they provide perfect breeding grounds for bacteria.

Tip.

To reduce the amount of steam during cooking always recommend reducing to simmer once boil is achieved. Always use lids on pots and pans, this increases pressure and saves energy.

Heat.

Most people find a room temperature of between 18°C and 22°C to be pleasant. If the temperature in the kitchen rises due to the heat generated by household appliances [oven, hob, refrigerators], it quickly becomes unpleasant – especially when compounded by humidity. These conditions also provide an ideal environment for bacteria and mould.

Room climate.

In addition to a mixture of moisture, grease and odours, which are collectively referred to as vapour, cooking also generates heat. All of these factors have various negative effects on the air, environment and furnishings.

Odours.

Cooking usually releases pleasant and appetising aromas. Once cooled down, however, these aromas tend to become unpleasant. The spread of odours to neighbouring rooms [living room, bedroom] is usually undesirable. If the odorous substances are not expelled from the house or filtered from the air, they can become trapped in many areas [particularly in textiles] and emit unpleasant odours throughout the entire room.

Operating Mode.

A Cooker hood draws in the vapours from the hob, filters them and releases the filtered air either to the outside atmosphere [extraction Mode] or back into the kitchen [recirculation Mode]. Whilst extraction mode is by far the more effective, the choice of modes depends on many factors.

At a glance.

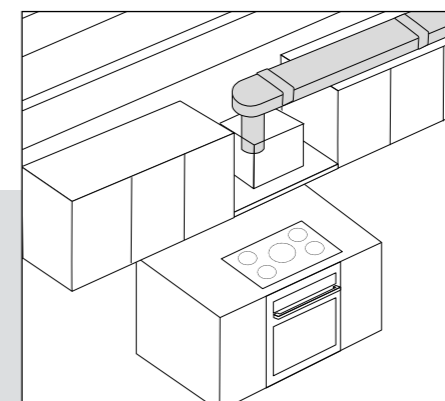
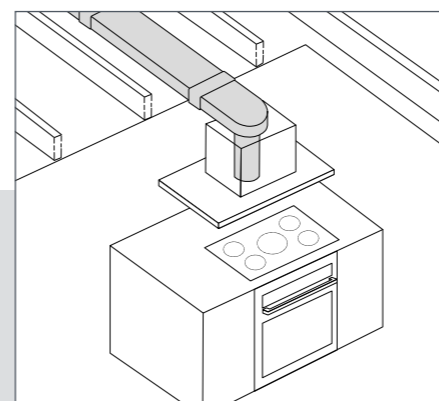

These diagrams are good examples of rigid ducting using 90 x 220 rectangular ducting, which is equivalent to 150mm diameter, 6 inch, also available at Caple.

Centrifugal fans are the main choice of fan for cooker hoods. Surface extraction units are characterised by very efficient suction at the centre of the cooker hood. Edge extraction units are often considered to be visually attractive and are characterised by high airflow speeds. This is especially beneficial when the hob and the hood are of the same width.

Odour filters are made of active carbon that binds and retains odorous substances. These active carbon filters must be changed on a regular basis. Some odour filters are washable and therefore have a longer service life. There are many different designs and styles on the market to cater for personal preferences cooking style and room conditions. Caple cooker hoods are now equipped with energy-saving LED lamps.

Caple cooker hoods offer remote or hob-based controls in addition to buttons or touch controls. The noise produced by a cooker hood depends on the installation + air flow rate. It can be expressed as a sound power rating dB [A] re 1 pW or sound pressure rating dB [A]. The power rating should also be taken into consideration when comparing cooker hoods. Where possible, the direction of the ducting should decline downwards slightly to the outside wall to prevent condensation running back into the hood, and onto your hob.

Standard hoods.

- › Always use semi or rigid ducting 6 inch [150mm diameter] circular or rectangular [90 x 220mm] unless specified differently in the instruction book.
- › To reduce the amount of 90° bends in the duct run and allow 1 metre reduction on run for every 90° bend.
- › Bends reduce air flow efficiency and increase noise level.
- › If ducting outside always try to use the shortest route. Try where possible to keep below 3 metres.
- › The vent to the outside should have slats as wide as possible so the air can flow out with minimum restriction and must be the same size as ducting, no reducers.
- › If air goes out, air has to come in. So it's important that the kitchen has fresh air supply, either through a window or an opening to the outside / other rooms.
- › Where possible, the direction of the ducting should decline downwards slightly to the outside wall to prevent condensation running back into the hood.
- › Always turn appliance on 10 minutes before cooking and run for 15 minutes after cooking.

Calculating the ventilation performance.

Ventilation performance [airflow rate] indicates how many cubic metres of air the cooker hood will displace per hour. It is expressed as m³/h. The required ventilation performance is determined primarily by the room volume [floor area x room height] and the required air exchange rate.

Ventilation performance is calculated as follows:

$$ER = RV \times A$$

ER = Required ventilation performance [extraction rate]

RV = Room volume

A = Air exchange rate

Example:

$$4\text{m}[\text{depth}] \times 4\text{m}[\text{width}] \times 2.7\text{m}[\text{height}] = 43.2\text{m}^3[\text{RV}] \times 10[\text{A}] = 432[\text{ER}]$$

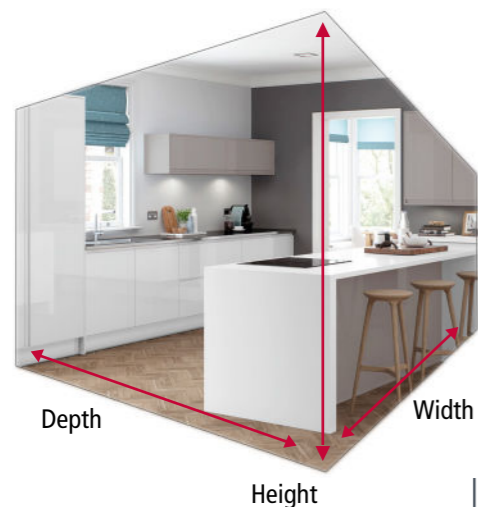

Kitchen fittings equate to around 20% of the calculated room volume. This can be either deducted from the room volume or retained as a performance reserve to compensate for any losses, for instance through active carbon filters.

According to current understanding, when performing the calculation for an open-plan living/kitchen area, only the effective kitchen surface area [without any deductions] needs to be used as the basis for the calculation, not the entire living area.

The air exchange rate describes how often the entire volume of air in the room needs to be re-circulated or replaced each hour.

Note that the air needs to be re-circulated more frequently in smaller rooms than in larger rooms. The lower volume of air in smaller rooms means that the vapour content in the room air increases relatively quickly, which results in the air becoming saturated more quickly and increases the need for more frequent recirculation or replacement.

To ensure optimal air purification, the hood used should exchange the air in the room 5 to 10 times per hour. This rate of air exchange is still low enough to prevent the formation of draughts. The required airflow rate is calculated for both minimum performance [for instance when simmering vegetables] and maximum performance [for instance when frying with lots of oil or fat]. To do this, multiply the room volume once by the lowest air exchange rate [A = 5] and once by the highest air exchange rate [A = 10]. You can then use this pair of values to identify a suitable appliance or performance level.

Example calculations.

Required ventilation performance	Small kitchen	Large kitchen
Width x Depth x Height = Room volume	10m ² x 2.5m = 25m ³	16m ² x 2.5m = 40m ³
To replace the air 5 times each hour, the minimum performance [e.g. for simmering]	125 m ³ /h	200 m ³ /h
To replace the air 10 times each hour, the maximum performance [e.g. for searing]	250 m ³ /h	400 m ³ /h

- › Cooking generates vapours containing grease, moisture and odours that condense on surfaces in the kitchen.
- › A cooker hood enables controlled air exchange.
- › The required ventilation performance of a cooker hood is calculated as follows: Ventilation performance = Room volume x air exchange per hour [max. 10 times].
- › Extraction and recirculation modes are available.
- › In extraction mode, the air is expelled to the outside to effectively remove humidity and odours.
- › In recirculation mode, the filtered air is fed back into the room. Humidity must be removed through additional intensive airing.
- › Grease is removed from the vapours by washable metal filters.
- › Active carbon filters in re-circulating hoods bind cooking odours. These must be replaced on a regular basis; Approximately every 6 to 9 months depending on use.

Tip.

The calculation of the theoretically required airflow rate does not take into account any losses caused by the exhaust ducting. Depending on the design of the exhaust ducting [length and cross section, surface quality, bends], the theoretically required airflow rate is reduced to an effective/actual rate. Any cross-flow of air in the room will also affect the effective extraction of vapours.

Width of the cooker hood.

The movement of air in the kitchen [cross-flow] causes the vapours created during cooking to spread more horizontally rather than vertically. They therefore tend to rise diagonally upwards. To ensure that all vapour can be extracted, the cooker hood should sufficiently cover the cooking area. The hood should be significantly wider

than the hob where possible; at the very least it should be of the same width. Island hoods in particular need to be wider and deeper than the hob due to the cross-flow of air in the room. Wall hoods with edge extraction are better at catching vapours due to the higher operating speed so a wall hood can be the same width as the hob.

Hob width	Recommended width of the cooker hood
Up to 60cm	60 - 70cm
Up to 70cm	70 - 90cm
Up to 90cm	90 - 110cm



Installation height + safe distances.

The installation height is primarily determined by the design of the hob and cooker hood. The distance between cooker hood and hob is usually between 65 and 76cm. Refer to the installation instructions for the individual cooker hood for further details. The larger distance is required for gas hobs.

Examples depending on model:

- › 650mm to 760mm for flat-screen hoods
- › 400mm to 450mm for angled extractors
- › 1500 mm for ceiling extractors

Observe the installation instructions and technical data provided with the appliances [cooker hood and hob].

Warning.

For safety reasons, it is important to observe the minimum recommended distance to the hob when determining the installation height for a cooker hood. Failure to observe this minimum distance can cause damage to heat sensitive components in the cooker hood.



When determining an installation height for a cooker hood, it is also advisable to ensure that the user has a clear view and unimpeded access to the hob/ cooking area. If this cannot be achieved using the values stated, the hood should be placed higher. However, the maximum distance of 760 mm or as stated in the installation instructions should not be exceeded. If the cooker hood is installed any higher, it will lose effectiveness and air extraction will be less efficient. If the cooker hood is to be installed at a greater height, it is advisable to adjust the hood width accordingly.



Important aspects of extraction or recirculation hoods.

Various aspects need to be taken into consideration when making a decision for a recirculation or extraction hood. The following is an overview of some of the more important criteria. For detailed explanations, please see the corresponding pages.



Recommended operating mode.

Extraction is still the most effective method of removing odours/vapours from the kitchen. Structural conditions and legal requirements have a significant influence when deciding which ventilation system to install in the kitchen. Heat loss throughout the house is becoming an important consideration.



Large gas hobs.

Recirculation hoods are not recommended for large gas hobs with a nominal output of between 11 and 18 kW [e.g. a gas hob with more than four burners or a gas hob with additional wok burner]. An extraction hood and sufficient intake air or a controlled domestic ventilation system must be provided. This must provide a minimum airflow of 15 m³/h per kW total nominal output. Appropriate intake air openings must be provided [technical regulations for gas installations].

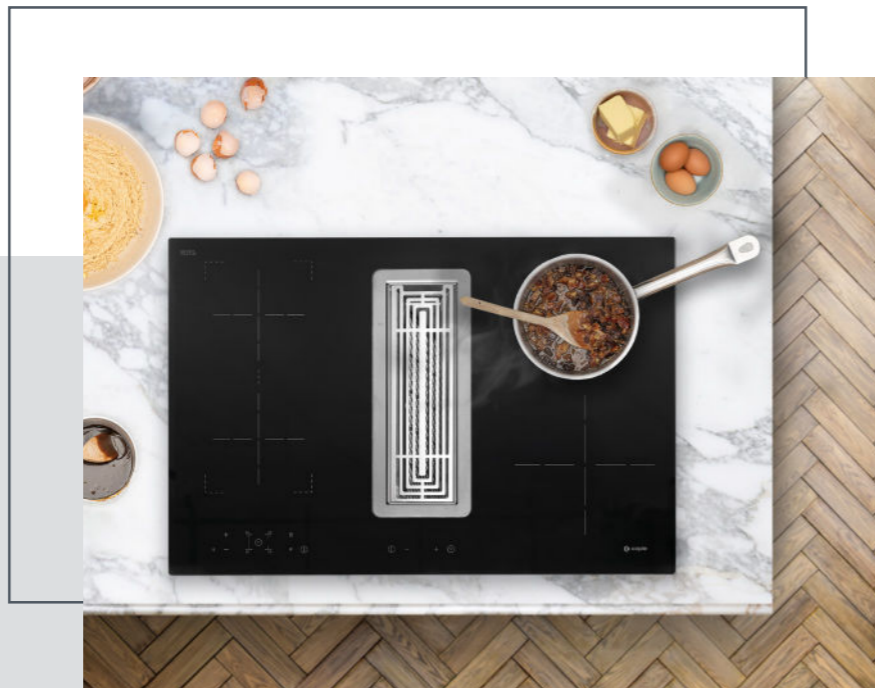

Woks, deep fat fryers, griddles etc.

Woks, deep fat fryers, grill pans and similar [griddles, teppan yaki, etc.] generate a great deal of heat in just a few minutes, causing rapid vapour generation. This can result in relatively strong development of smoke and vapour. The following aspects should therefore be taken into consideration when planning the use of a cooker hood above these types of cookware:

- › An extraction mode should always be used rather than a recirculation mode.
- › This method is particularly effective at cleaning the room air as it draws smoke and heat outside.
- › If possible [e.g. when arranging individual cooking areas or modular systems], woks, deep fat fryers, grill pans etc. should always be placed centrally under the cooker hood.
- › Cooker hoods that extract air over an entire panel [surface extraction] or feature multi-zone edge extraction are better suited than hoods with edge extraction. These are better at capturing the vapour from this type of cooking, which is generated centrally and rises relatively steeply.

Aspects to note	Operating modes	
	Extraction	Recirculation
Grease filter	Required	Required
Energy efficient house low energy house	Discussion required with architect, ventilation engineer, kitchen designer Etc	Possible: discussion required with architect, ventilation engineer, kitchen designer Etc
Energy efficient house passive house		
Extractor ducting	Required [Rigid]	Not required
Wall vent	Required [Rigid]	Not required
Open fire places	Ensure intake air supply	Possible
Intake air	Required	Not required
Room airing after cooking	Not required	Required
*Grill pans, Woks, Deep fat fryers	Recommended	Not recommended
*Large Gas hob [more than 11kW]	Recommended	Not recommended

*Use higher extraction rate hoods

Planning exhaust air ducting.

The effectiveness of the cooker hood system results from the interplay between the cooker hood and the exhaust duct components, the

Characteristic curve of a cooker hood.

The characteristic curve of a cooker hood shows how it behaves under different operating conditions. This diagram shows the relationship between counter pressure and airflow rate for a specific cooker hood and connected ducting, as well as the relationship between counter pressure and the noise level [acoustic power]. Characteristic curves X, Y and Z show these relationships for the three power settings on the cooker hood.

For example, the point where characteristic curve Z intercepts the baseline [x-axis] shows that the airflow rate for this hood is 460 m³/h at power setting 3 [characteristic curve Z] and 0 Pascal counter pressure. Counter pressure of 0 Pascal exists only when the airflow rate is measured directly at the fan outlet of the cooker hood [= free blowing. When the counter pressure increases [e.g. by connecting the extractor ducting], the airflow rate decreases.

Characteristic curves A, B and C show how greatly the two values change when three sets of example extractor ducting [with different cross sections] are connected. If the extractor ducting with characteristic curve C is connected, for example, the counter pressure increases to 70 Pa and the airflow rate falls to 440 m³/h. However, if the extractor ducting with characteristic curve A is connected, the counter pressure increases to 180 Pa and the airflow rate falls to 385m³/h. In general, the following applies: the lower the counter pressure following connection of extractor ducting, the lower the impact on the airflow rate of the hood.

The extractor ducts with characteristic curves C and A primarily differ in terms of their cross section. In general, the larger the ducting cross section, the lower the counter pressure and the higher the airflow rate. Extractor ducting with larger cross sections should therefore be the preferred approach. However, the level of counter pressure is not only influenced by the cross section of the extractor

decisive factor here is to keep the frictional resistance in the ducts as low as possible to prevent any reduction in extractor performance.

ducting. It also depends on the structural design of the extractor ducting [material and shape, changes in cross section, number of bends etc.]. The less favourable the layout, the more vertical the ensuing characteristic curve. When designing the extractor ducting layout, all necessary measures must therefore be taken to keep the counter pressure created by connecting the ducting to a minimum.

The diagram also shows that an increase in the counter pressure in the extractor ducting also involves an increase in the noise level [acoustic power]. In this case, reducing the cross section of the extractor ducting from 150 mm [curve C] to 100 m [curve A] causes the acoustic power to increase from a whisper-quiet 49 dB [A] re 1 pW to 70 dB [A] re 1 pW, which is as loud as a vacuum cleaner. This is another reason why the counter pressure created when connecting the ducting should be kept to a minimum. Poor extractor ducting cannot be compensated for by using a more powerful cooker hood. This would simply increase the level of loss and generate more noise.

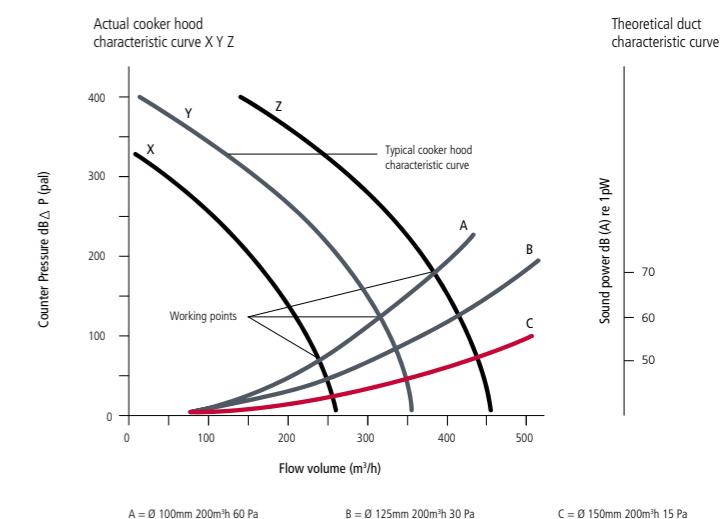



Information on exhaust air ducting.

The planning and design of extractor ducting has a significant influence on the airflow rate and the noise level of the cooker hood. This is because each component in the ducting introduces counter pressure [frictional resistance], which leads to a reduction in the airflow rate in the cooker hood and increases the level of noise.

The frictional resistance within the ducting is dependent on a number of factors:

- › Cross section of the exhaust air ducting
- › Length of the exhaust air ducting
- › Bends/curves in the exhaust air ducting
- › Material and type of ducting [the material must also be approved for use with a cooker hood in accordance with fire prevention regulations]



Cross section of the exhaust air ducting.

The cross section of the ducting must be adapted to match the airflow rate of the cooker hood and the ducting routing [length and design]. A cross section that is too narrow will result in significant losses in the airflow rate and increase the noise level. The ventilation performance of the cooker hood is the key factor for determining the ducting cross section. The more powerful the ventilation performance, the greater the ducting cross section must be. As a rule, the larger the cross section, the less counter pressure is created in the ducting.

The following exhaust air ducting specifications serve as a guide:

- › Ø125 mm for a ventilation performance of < 400 m³/h
- › Ø150 mm for a ventilation performance of > 400 m³/h

Any reduction in the cross section of the ducting must be avoided. This would give rise to turbulence, which would generate a high amount of counter pressure. The more rapid airflow speed associated with a narrowing in the cross section will also cause the noise level to increase. Unavoidable reductions in the cross section should always be made at a flat angle [not a 90° angle]. This is the only way to keep air turbulence and increased counter pressure to a minimum. By contrast, increases in the cross section have a positive effect on counter pressure.

Tip.

It is only possible to achieve a high airflow volume and low noise level by using extractor ducting that provides low resistance. Always use where possible rigid ducting equivalent to 150mm diameter.

Exhaust material ducting + shape.

Smooth-walled plastic rigid ducts are the most favourable form of ducting from a technical airflow perspective and are particularly suitable for straight duct routes/runs. These should be used if the structural requirements are met.

Flexible aluminium ducting [alu-flux] also achieves reasonably good flow values when elongated. It is more flexible than rigid plastic ducting and adapts well to differing structural conditions. Unnecessary bends should, however, be avoided.

Corrugated and spiral ducts are the least favourable from a technical airflow perspective. The wave-like surface results in a large amount of turbulence, even if the ducting is pulled taut. When the film is heated by the extracted air, it stretches. This leads to even greater turbulence and the flapping film generates noise. This type of ducting is prone to crushing which will create poor air flow.

A distinction is made between round and flat channels. Flat channels are often used in practice for both visual and technical reasons. It used to be believed that the flow conditions in flat channels were less favourable. However, this no longer applies as a general rule. Recent developments in flat channels can provide similar or better airflow results than a round channel. They are characterised by the following features: The inner cross section of the flat channel must correspond at least to the cross section of the exhaust air socket in the cooker hood. The surface area should therefore equate to the cross section of a 150mm pipe if the exhaust air outlet has a diameter of 150mm.

The width-to-height ratio must be optimised. The higher the flat channel, the more favourable its airflow qualities [e.g. 90 x 220mm]. Supplied by Caple.

Flow resistance: low

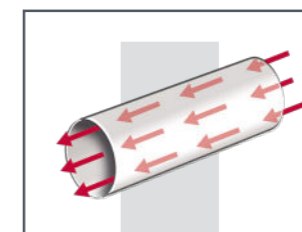

Rigid Smooth-walled ducting

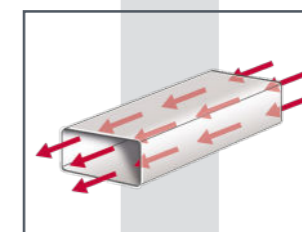

Rigid High flat channel

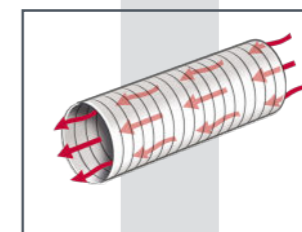

Aluflex ducting

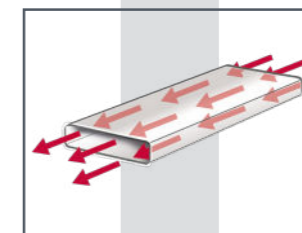

Rigid low flat channel

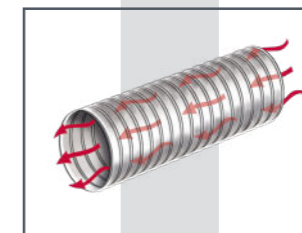

PVC Flexible tubing

Flow resistance: high

Length of the exhaust ducting, curves + bends.

As the length of the exhaust ducting increases, the counter pressure [duct resistance] increases and the airflow rate decreases.

Bends and curves are problematic as they present deflection surfaces that dam the air stream and generate turbulence. This causes an increase in counter pressure.

Bends and curves in the ducting should therefore be kept to a minimum. If bends and curves are required for structural reasons, bends with the largest possible radius are advisable. The smaller the bend radius, the greater the counter pressure. Corners at right angles should also be avoided if possible because these lead to even greater pressure losses and therefore a loss of performance.

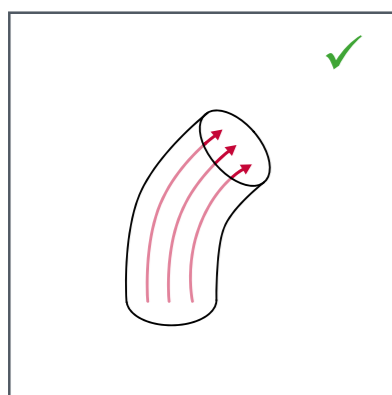

45° bend.
Advisable.

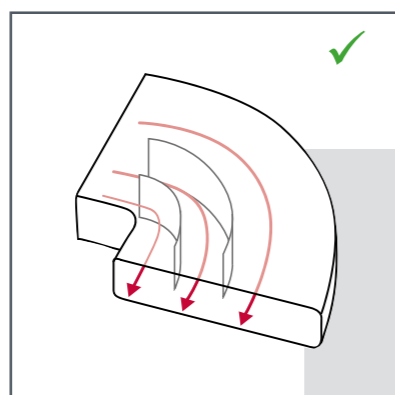

90° bend with guide plates.
Recommended.

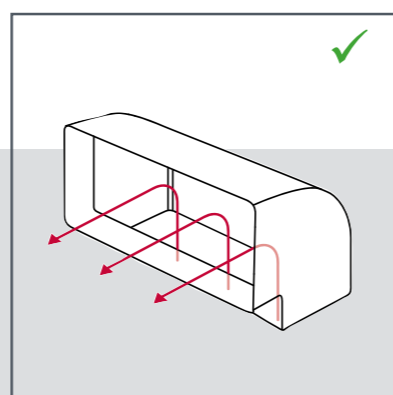

90° bend.
Recommended.

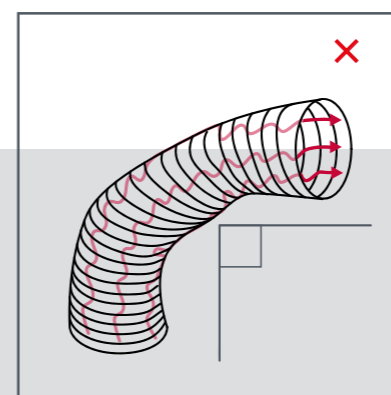

Flexible PVC hose.
Do not use flexible PVC hose.

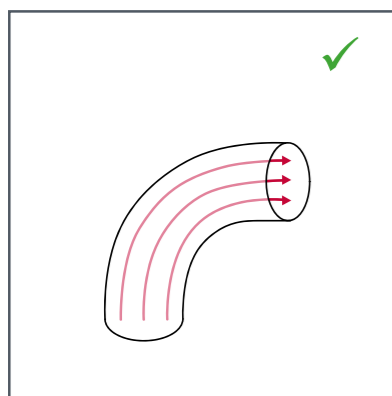

90° bend.
Advisable.

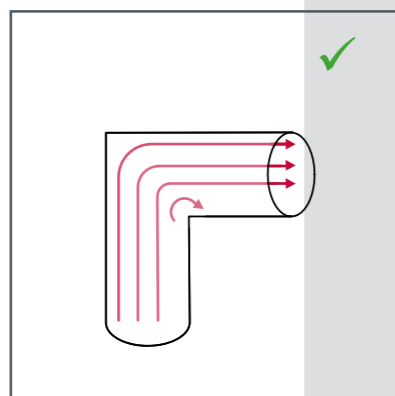

90° square bend.
Ok to use, however will increase noise level / decrease air flow.

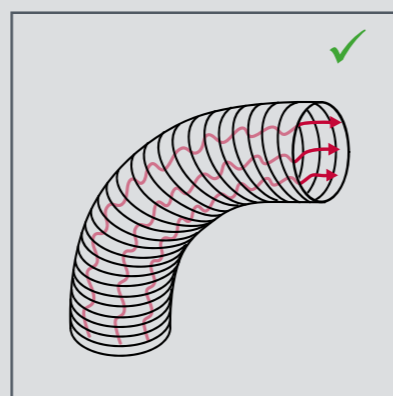

90° bend semi rigid.
Advisable.

Tip.
The following rule of thumb applies for good duct routing: the distance between two bends should be at least 1m, although 1.5m is better.

The more efficient corner will see the products increase in performance. This can be demonstrated by the below example of the current 2653W kit. The black line is the current version and the green is the new, you can see the pressure build up in the new duct kit is around 15% less therefore improving the overall performance.

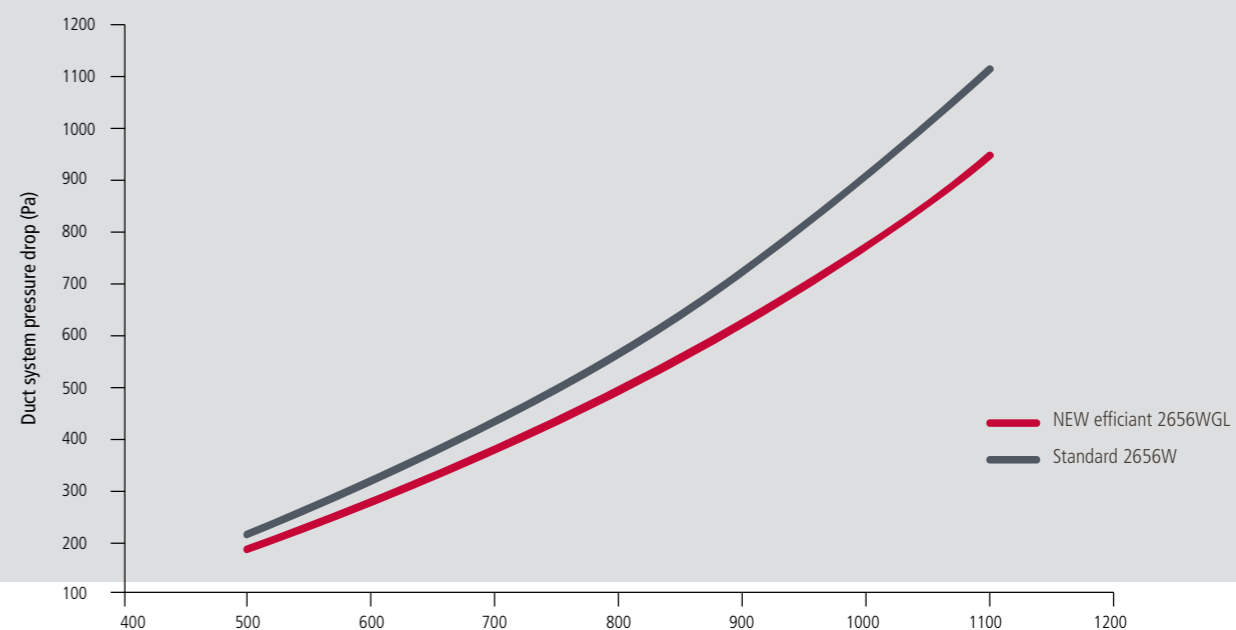

Ducting comparison.

The following comparison between different duct types and flat channels indicates the extent to which the material used can influence airflow loss.

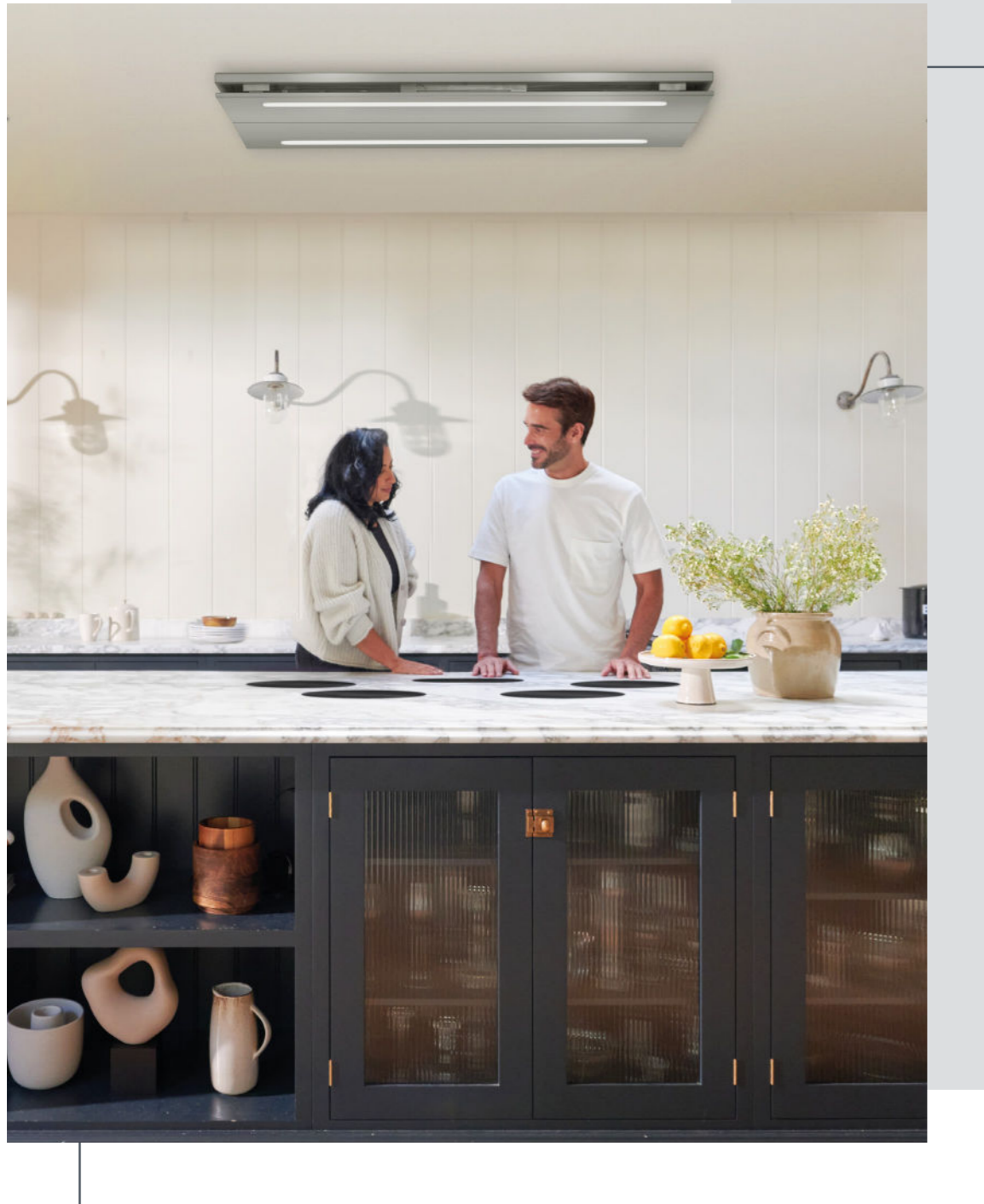

Comparison between channel system with a square cross section.

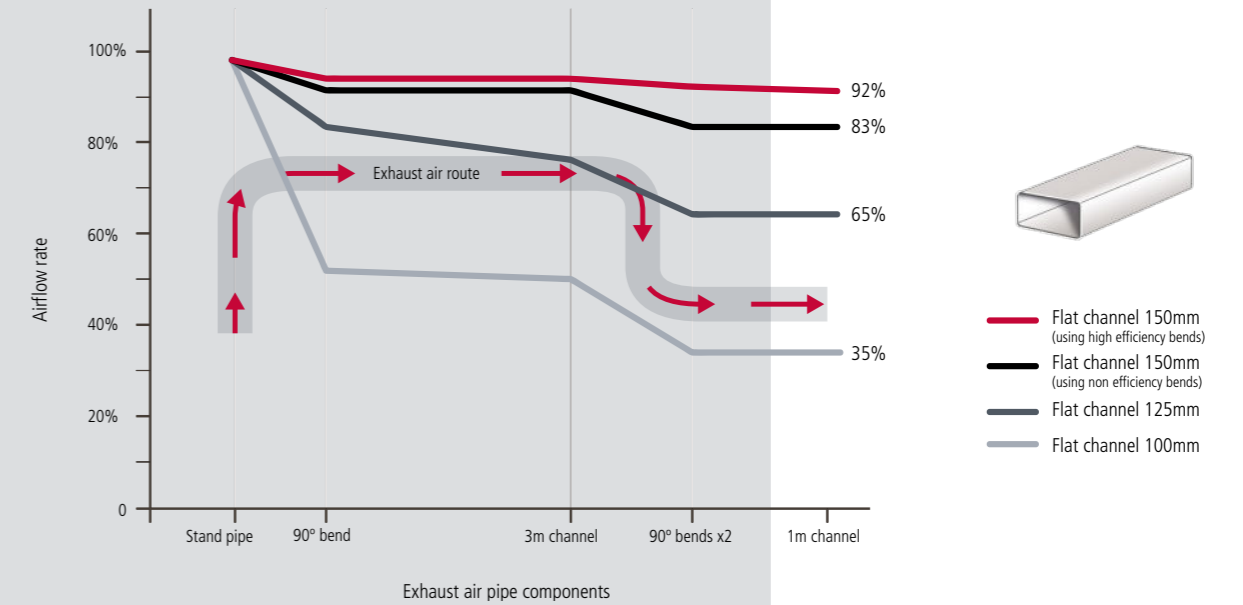

Comparison between channel system with a ROUND cross section.

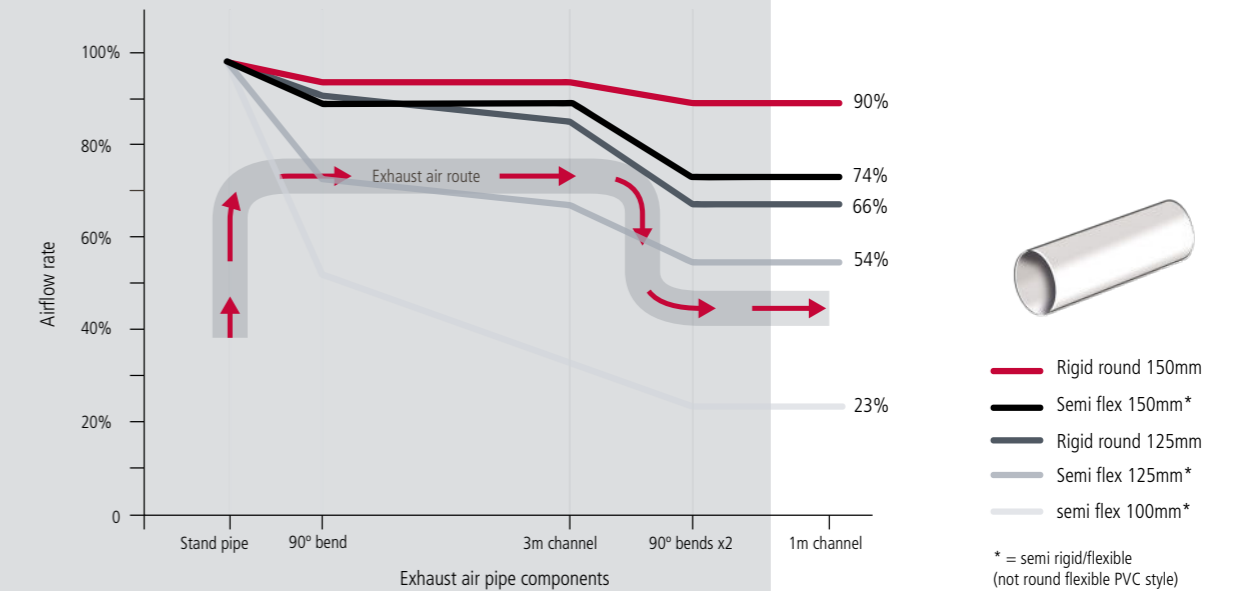

Back pressure.

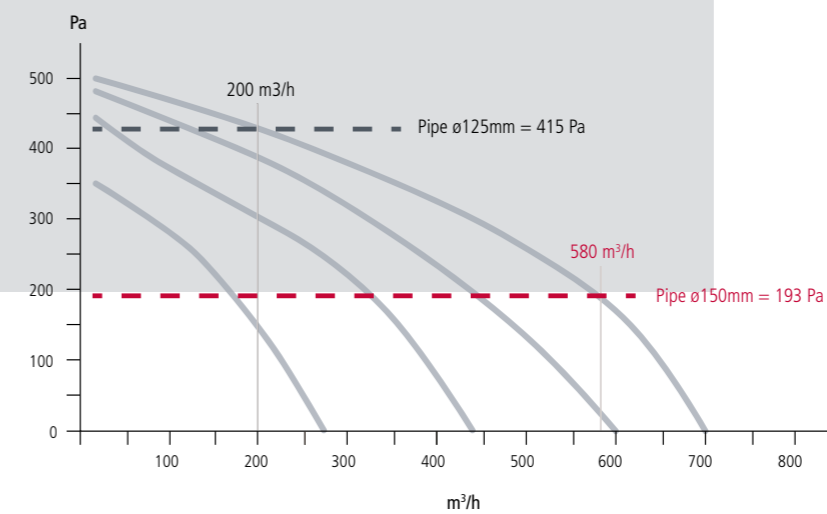



Condensation in the exhaust duct.

Condensation can form when the warm extracted air flows through cooler ducting. To allow the condensate to drain, level extractor ducting can be installed with an angle of inclination of approx. 2° to the exterior wall.

Wall vent.

An exhaust air wall vent covers the opening in the wall and is used to convey the exhaust air from a cooker hood outside. It needs to be designed so that the exhaust air can flow out with as little pressure loss as possible.

Conventional exhaust air wall vents consist of an exterior cover, usually in the form of rigid gravity flaps, and an internal back flow trap that prevents the unwanted ingress of outdoor air. Depending on the design of the gravity flaps, the air stream is deflected to a greater or lesser extent, which can result in large pressure losses. This significantly reduces the efficiency of the cooker hood and increases the level of noise.

Why does exhaust air need intake air?

A cooker hood that expels air from the kitchen to the outside atmosphere needs an equal amount of intake air to ensure the cooker hood works to full efficiency.

Exhaust air needs intake air.

When cooker hoods are operating in extraction mode, the filtered room air is conveyed outdoors and thus leaves the room. If none or too little fresh air flows back into the kitchen from outside, negative pressure is created.

If the negative pressure is not equalised it will lead to an increase in the hood's motor speed and noise level and also to a reduction in airflow and air exchange.

As odorous substances will remain in the room, the air purification is significantly lower. Extraction hoods must have sufficient intake air - equal to the amount they expel to the outside. Natural ventilation is normally sufficient for a kitchen/dining area.

To ensure that the vapours rise vertically to the cooker hood for extraction and are not blown away by the incoming air, steady air circulation must be provided in the kitchen and intrusive cross-flows or air turbulence must be avoided. In an ideal situation, cold air will enter the room from a vent in the wall opposite the cooker hood.

This cold air will capture any existing vapours in the kitchen as it drops. As it then rises above the hob, it will capture as many of the vapours there as possible and expel them via the hood.

The following points must be taken into consideration in order to come as close to this ideal scenario as possible:

- » The intake air should come from the opposite side of the room where possible.
- » If the intake air is provided by an open window on the opposite side of the room, other windows and doors should remain closed.
- » If possible, install the ventilation grilles and wall vents directly beneath the ceiling [not close to the floor].
- » The intake air element should be located at least 2m from the cooker hood.

Ambient air heating appliances.

The following notes apply to extraction hoods [not to recirculation hoods] in combination with heating appliances dependent on a flow of ambient air [not for self-enclosed heating appliances]:

When installing an extraction hood in rooms with heating appliances dependent on ambient air such as wood burners, open fires or gas-fired boilers, it is essential to ensure a sufficient supply of intake air. This is because operating both simultaneously can result in negative pressure strong enough to prevent the combustion gases from escaping through the chimney/flue and can draw the gases into the room instead. Combustion gases are toxic and can prove harmful or even fatal to the occupants.

Please refer to the relevant Gas safe code of practise or a registered gas safe engineer.

The installation of an exhaust/intake air wall vent may provide sufficient intake air in individual cases. In most cases, however, the cross section of the air intake in wall vents is not sufficient to ensure that the negative pressure does not exceed 4 Pa.



The technology of cooker hoods.

Most cooker hoods feature the same basic design. They all have a grease filter. Re-circulation hoods also have an active carbon filter. The main differences with regard to efficiency and noise levels lie in the type of motor/fan and also whether kitchen vapours are extracted via edge or surface extraction.

The fan is the heart of every cooker hood. It comprises a fan wheel and a motor. The fan draws up and expels kitchen vapours. The fan is usually incorporated in the hood assembly. Most cooker hoods use centrifugal fans.

Centrifugal Fan.

In units with centrifugal fans, the air is drawn in parallel or axially to the fan/rotor disc drive axis, diverted 90° by the rotation of the radial rotor disc and blown out radially to the drive axis.

The centrifugal force of the rotating fan blades causes pressure acceleration of the air stream, which is further heightened by a narrowing in the outlet cross section of the fan housing. The generation of this relatively high pressure potential is the key benefit of a centrifugal fan. This type of fan is therefore particularly well suited to longer stretches of ducting with a narrow cross section. Centrifugal fans achieve airflow volumes from 250 to more than 800m³/h and are the preferred design for cooker hood assembly. Most cooker hoods use centrifugal fans.

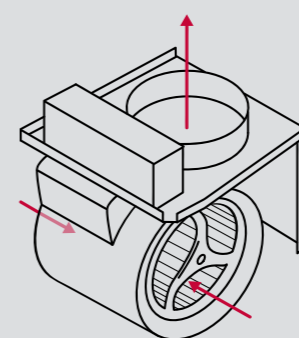

Grease Filters.

All cooker hoods are fitted with grease filters. These are designed to trap the grease particles contained in the vapour when air passes through the filter. The grease is filtered out of the vapour to protect both the kitchen and the cooker hood itself [particularly the motor and ducting] from grease deposits. When new or kept in a properly cleaned condition, all grease filters are non flammable or fire retardant and self-extinguishing.

The ability of a filter to capture grease is limited. Depending on the use, grease filters must be replaced or cleaned regularly. This is required to prevent the formation of undesirable and unhygienic grease deposits and also to minimise the risk of a grease fire. When new or kept in a properly cleaned condition, all grease filters are non flammable or fire retardant and self-extinguishing. The ability of a filter to capture grease is limited. Depending on the use, grease filters must be replaced or cleaned regularly. This is required to prevent the formation of undesirable and unhygienic grease deposits and also to minimise the risk of a grease fire.

Metal grease filters/mesh filters.

These are permanent filters that can be used for years without restrictions if properly cared for. Depending on its construction, a mesh filter can consist of between 4 and 12 aluminium or stainless steel mats in a filter frame.

Metal filters need regular cleaning — this can be between 15 and 100 hours of operation depending on the model, but at the latest when the noise starts to get louder. A metal grease filter can be soaked and cleaned by hand. However, it is usually easier to clean them in the dishwasher.

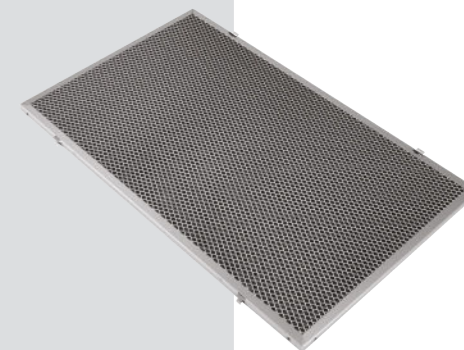

Setting.

Intensive programme [60–70°C]. To prevent any dirt entering the mesh from other crockery and becoming trapped, mesh filters should be cleaned in the dishwasher by themselves.

Note:

Aluminium grease filters may discolour to light grey or take on a matt appearance due to the effects of aggressive, acid components in the grease particles or aggressive components in dishwasher detergent. This does not, however, have an impact on the filter's efficiency. Some designs have filter mats with perforated stainless steel covers. The grease in filters that are not cleaned for extended periods can solidify and will not be removed during cleaning. In such cases the filter will have to be replaced. Filters are held in place on the cooker hood by various fastening mechanisms.

Odour filter, Active carbon filter.

Odour filters are required only for cooker hoods that re-circulate the air. They are not necessary for extraction hoods as the vapours containing the odour are transported outdoors. In an activated carbon filter, odorants are captured on the surface of the carbon [adsorbed]. To enable the maximum amount of odorants to be filtered out, the carbon surface must be very large.

The carbon particles achieve this through a combination of their small size [diameter of 3–4 mm] and the fact that they are porous or riddled with narrow channels. This means that just 8g of activated carbon granules has the same surface area as a football pitch. The flow speed of the air must, however, not be too high. The fan and filter type used in cooker hoods must therefore be carefully matched. The high absorption rate can only be achieved if the active carbon filter is replaced/cleaned on a regular basis, every 6 to 9 months.

The grease filter [typically installed upstream of the active carbon filter] must also function correctly. Any grease particles that enter the activated carbon filter are deposited, which blocks the channels in the carbon pellets and significantly impairs the odour filter's function. It is therefore necessary to carefully change and clean both filters on a regular basis to ensure that the cooker hood operates correctly.



Active carbon filters.

This type of filter cannot be washed. Disposable active carbon filters should be replaced approx. every 6 months or after 120–200 hours of operation, depending on the type of cooker hood.

Refer to the operating instructions for further details. In disposable active carbon filters, the carbon particles are loosely distributed and contained in a paper sleeve inside a round or rectangular filter cassette. With filter cassettes in which the particles can move around, ensure that the particles are evenly distributed before the cassette is inserted into the filter. This will ensure that odorous vapours come into contact with a similar number of carbon particles at any given point across the filter surface.

Operation.

Each cooker hood is equipped with controls to regulate the power output. These controls can be push buttons, touch operation, slide controls and remote controls.

Tip.

The cooker hood should be switched on 10 minutes before starting to cook so that the air in the kitchen starts to move in good time. Once cooking is finished, the fan should be left to run for 15 minutes so that odours in the room can continue to be absorbed and the active carbon filter can dry out. Kitchens with a recirculation hood should be aired after cooking to remove moisture from the room.

Ventilation performance / airflow rate.

Caple measures the airflow rate of cooker hoods [performance data] exclusively in accordance with the BS EN 61591 standard. The measurement set-up specified in this standard is based on commonly available extractor ducting arranged to provide a counter pressure of 15 or 30 Pascal at an airflow rate of 200 m³/h.

In practice, this corresponds to:

- › A straight duct length of around 4m or
- › A run of extractor ducting comprising a vertical 30 cm section [from the fan outlet upwards], a 90° bend and a horizontal section of 1m

The "free-blowing" value that is often provided as an alternative is of less use to the consumer as it does not apply to practical use. To obtain this value, the measurement sensor is placed directly at the fan outlet and the ducting is not taken into account.

Hoods + extractors.

Noisy.

- › Check that the hood has correct size ducting [semi or rigid only- do not use flexible PVC].
- › Make sure there are no restrictions within the ducting or outlet.
- › Make sure the minimum amount of 90 degree bends have been used.
- › Make sure the hood has been secured to the wall correctly as per instructions [fixing screws used to secure].
- › Make sure cable hasn't been dropped into fan area.
- › Make sure no plaster or rubble has dropped into fan area.
- › Make sure spigot outlet flaps have not been jammed semi closed against ducting.
- › In re-circulation mode make sure the flue vents/grilles are not covered.



Poor extraction.

- › Check that the hood has correct size ducting [semi or rigid only- do not use flexible PVC].
- › Make sure there are no restrictions within the ducting or outlet.
- › Make sure the minimum amount of 90 degree bends have been used.
- › Make sure spigot outlet flaps have not been jammed semi closed against ducting.
- › Make sure ducting doesn't exceed recommended length run for the model installed.
- › Make sure customer is switching hood on 10 minutes before cooking + leaving on 10-15 minutes after.
- › Advise customer to always reduce boiling water to simmer + use lids.
- › On re-circulation mode it is more important to use lids on pots/pans to reduce steam/humidity in room.



Efficient installation.

As every installer should know, high quality ducting is essential to the effective running of a ventilation system and there are a number of important considerations to take into account.

When ducting is selected and installed correctly, it can improve and prolong the efficiency of the whole system, leading to long term low maintenance. On the other hand, a ventilation system that has issues with the ducting, which can range

from 'slump' of flexible types, through to inadequate jointing mechanisms, is always going to under perform. Poorly installed duct work can potentially damage the ventilation unit and the fabric of the building.

Below are real examples of poor installation, **do not** follow them. This may invalidate the warranty and will result in the substandard performance from the extractor. Poor installation may also have a negative reflection on the retailer and the product.

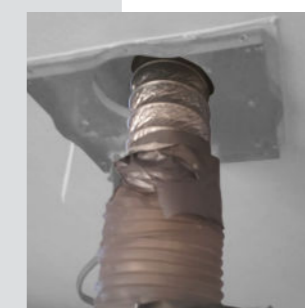
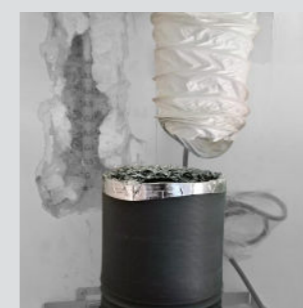

Trouble shooting.



Please make sure the below has been checked before logging a service call.

Downdrafts.

Noisy.

- › Check that the ducting is rigid + correct size [important - do not use semi or flexible or reduce ducting size].
- › Make sure there are no restrictions within the ducting or outlet.
- › Make sure the minimum amount of 90 degree bends have been used.
- › Make sure the maximum ducting length hasn't been exceeded – 5 metres + reduce by 1 metre for every 90 degree bend used.
- › Make sure spigot outlet flaps have not been jammed semi closed against ducting.
- › In re-circulation mode make sure there is a vent or cut out in the plinth to allow air to escape + release back into the room.
- › Juddering noise – please check the downdraft is central + correctly fitted into worktop, make sure fixing brackets at the bottom are central + not pushing or pulling the appliance out of square or twisting body.
- › Make sure correct screws have been used + longer ones haven't been used as they will push against the runners.

Poor extraction.

- › Check that the ducting is rigid + correct size [important - do not use semi or flexible or reduce ducting size].
- › Make sure there are no restrictions within the ducting or outlet.
- › Make sure the minimum amount of 90 degree bends have been used.
- › Make sure spigot outlet flaps have not been jammed semi closed against ducting.
- › Make sure the maximum ducting length hasn't been exceeded – 5 metres + reduce by 1 metre for every 90 degree bend used.
- › Make sure downdraft is within 50mm of hob.
- › Make sure customer is switching hood on 10 minutes before cooking + leaving on 10 -15 minutes after.
- › Advise customer to always reduce boiling water to simmer + use lids.
- › On re-circulation mode it is more important to use lids on pots/pans to reduce steam/humidity in room.



Guidelines + recommendations.

Please refer to **Gas safe + domestic ventilation compliance guide.**

- › The cooker hood should be wider than the hob; at the very least it should be of the same width.
- › Compliance with the minimum distance between the hob and cooker hood as specified by the manufacturer is mandatory.
- › Specific hob characteristics [gas hob, deep fat fryer, etc.] must be given due consideration.
- › Select the largest possible cross section.
- › Use rigid pipes and channels with smooth walls.
- › The higher the flat channel, the more favourable its airflow qualities.
- › The exhaust air duct should be rigid, as short and straight as possible with no reducing adapters and as few diverters as possible.
- › Diverters [90° bends, etc.] with internal guide plates are best for maintaining the ventilation performance.
- › Wall vents that are air-tight when closed cause less heat loss and are therefore highly advisable; some may also be suitable for energy efficient houses.
- › Exhaust air needs intake air ensure an adequate intake air source is available.
- › Legal requirements must be considered before installing an extraction hood. Please consult gas safe regulations.
- › An intake air source is mandatory for heating appliances dependent on ambient air [e.g. wood-burning stoves], Please consult gas safe regulations BSEN 61591.

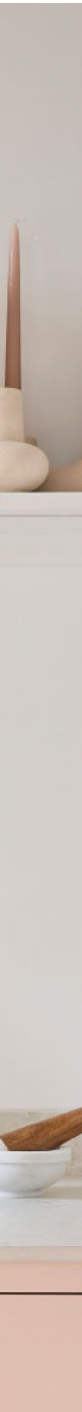

Fourth Way
Avonmouth
Bristol
BS11 8DW

t: 0117 938 1900
f: 0800 373 163
e: sales@caple.co.uk
caple.co.uk

